

Revisions			
Rev	Description	Date	Initials
A	Next revision, updated from old database	10/4/2010	TPA
B	Updated drawing to match actual mold features and dim	3/26/2014	DVK

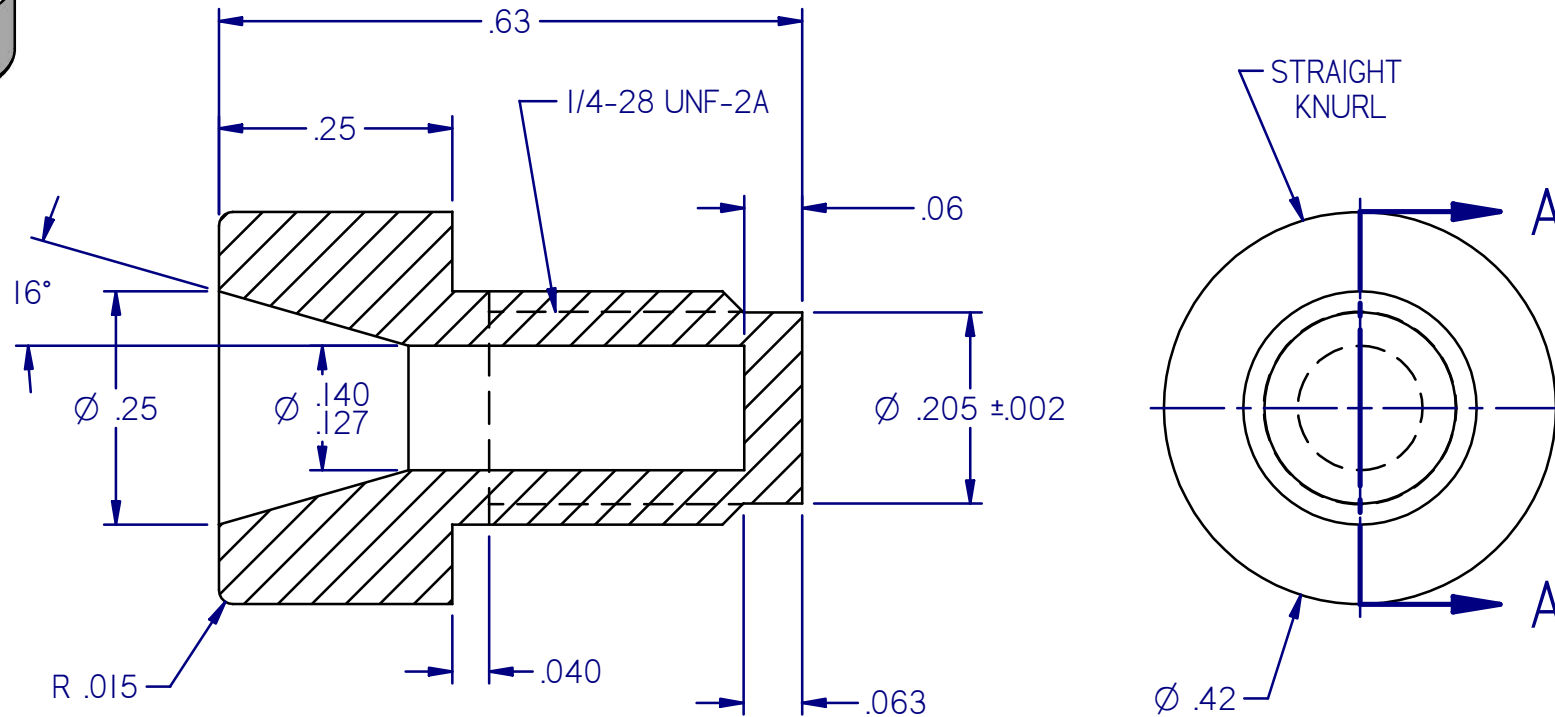

SECTION A-A

NOTES:

1. REMOVE ALL BURRS/FLASHING.
2. SURFACE FINISH AS MOLDED.
3. ALL RADII ARE TO BE .031" MAX. UNLESS NOTED.
4. ALL DRAFT ANGLES ARE TO BE 1° MAX. UNLESS NOTED.

CONFIDENTIAL:		GRACE Davison		GRACE Davison Discovery Sciences 2051 Waukegan Road, Deerfield, IL 60015 (847) 948-8600	
This drawing is the property of Alltech Associates, Inc. Any reproductions or modifications of this drawing or its contents without consent of Alltech is prohibited.		DESCRIPTION: 1/4-28 Plug			
MATERIAL: PEEK			P/N: 2110831		
GENERAL TOLERANCES DECIMAL: XX ±.010"; XXX ±.005" FRACTIONAL: ± 1/64" ANGULAR: ±1/2° UNLESS OTHERWISE SPECIFIED		DRAWN: DVK		APPROVED: SPS	
63/ ✓		SCALE: 5 = 1		DATE: 03/26/14	
		SIZE A		DRAWING NO: 0001432	
		REV B		SHEET 1 OF 1	